

FISHER *m-SCOPE*®

CZ-5 Quicksilver

**Deep Search, Target I.D. Metal Detector with dual
Fourier Domain Signal Analysis**



Operating Manual

FISHER RESEARCH LABORATORY

CONTENTS

| | |
|---|--------|
| About Your CZ-5 Quicksilver | pg. 1 |
| Condensed Operating Instructions | pg. 4 |
| Factory Preset "Turn-On-And-Go" Marks | pg. 4 |
| Setting Up | pg. 5 |
| Hipmounting | pg. 7 |
| Control Panel | pg. 7 |
| Turn-On Procedure | pg. 9 |
| Ground Balancing | pg. 9 |
| Pushbutton Method | pg. 10 |
| "Bobbing" The Search Coil Method | pg. 11 |
| Search Modes | pg. 12 |
| Auto Tune | pg. 12 |
| Target ID | pg. 13 |
| Searching | pg. 17 |
| Pinpointing | pg. 20 |
| Pushbutton Pinpoint Mode | pg. 20 |
| Target ID and Autotune Modes | pg. 21 |
| Target Identification | pg. 22 |
| Depth Reading | pg. 23 |
| Target Recovery | pg. 24 |
| Recovery Tools | pg. 25 |
| False Signals | pg. 25 |
| Operating Tips | pg. 29 |
| Battery Replacement | pg. 32 |
| Maintenance | pg. 33 |
| Treasure Hunter's Code Of Ethics | pg. 34 |
| Where To Use Your Metal Detector In The U.S. | pg. 35 |
| Specifications | pg. 36 |

ABOUT YOUR DETECTOR

Your CZ-5 Quicksilver is an extremely advanced and sophisticated instrument.

VISUAL TARGET IDENTIFICATION. An easy-to-read meter displays seven small-target categories. Silver and gold bands across the top indicate the most likely categories for small gold and silver targets. When the dual frequency CZ-5 classification circuitry makes identification, the needle *locks* over the center of the appropriate category. If ID is difficult due to irregular size, conductivity or depth, the CZ-5 will alert you to this by jumping back and forth between the most likely categories. What it will *never* do is lock-on between categories or gives you a series of numbers to interpret. No programming, no razzle-dazzle, no nonsense.

AUDIO TARGET IDENTIFICATION. A low tone means a ferrous or iron target: a medium tone indicates a pull-tab or foil; and a high tone means you've probably found a coin. The tone ID *always* agrees with the meter ID. If the audio response tone is low, the meter will always read "iron" and if the tone is high, the meter will always read in one of the coin categories.

PUSHBUTTON DEPTH READING, VCO PINPOINTING. Just push a button and the volume, pitch and meter needle will rise as you approach your target and then peak right over it. The meter gives you a depth reading in inches for coin-sized objects.

WET SAND OPERATION. Salt water is no problem for the CZ-5. Just flip a switch, reset your ground control and search that wet sand you never could before, in fact you can submerge the coil in salt water and search as though it wasn't even there. The CZ-5 compensates for salt and sand simultaneously.

TARGET SEPARATION. It's a sad but true fact that most gold rings, pull tabs, foil and nickels fall into the same conductivity range, meaning that a detector user has to dig a lot of trash to find any rings or nickels. But not any more. The CZ-5 not only separates the nickels from the trash, but the tabs from the tabs. It has a separate ID and discrimination categories for round pull tabs, rectangular pull tabs, foil and nickels. Rather than a complicated "notch" system, the individual categories are sequentially arranged to insure maximum good target recovery. In a moderately trashy area for example, you can set the CZ-5 to reject iron and

round pull tabs and still dig nickels and other coins and all gold rings falling into the nickel, foil and rectangular tab and nickel categories.

BIG TARGET ALERT. Large shallow (like a jar lid or a beer can) overload metal detector circuits making accurate target ID or trash rejection impossible. But not with the CZ-5. Whenever it passes over a large shallow target, a distinctive bell-tone immediately warns you that the target is too large to identify.

DEPTH. Target identification in air is easy for just about any ID metal detector. But the CZ-5 does it in the ground and does it deeper. Thanks to the patented Fourier Domain Signal Analysis System, the CZ-5 can identify deeper targets in mineralized soil. *Two* VLF ground compensation signals are transmitted (one at 5KHz, one at 15 KHz), giving the circuitry two ground compensated target response signals to analyze, compare and identify.

SILENT SEARCH, SLOW MOTION DISCRIMINATION. No threshold, no clicking, no popping, no static. Once you set the CZ-5 discrimination control to one of its six factory calibrated lock-on discrimination points, the audio and visual target identification circuits will completely ignore everything identified as belonging in a category below that discrimination point. For example, a setting of "4" tunes out iron, pull tabs and foil. As long as you're at this discrimination point you'll never hear the low "iron" tone or the medium tone of pull-tabs and foil. And since the discrimination categories are exactly the same as the meter categories, the meter will never ID iron, pull tabs or foil as long as you remain at "4". Any false signal you do hear or see will be in the "coins" category only because the CZ-5 couldn't positively identify the target as iron, foil or a pull-tab.

AUDIO BOOST VOLUME CONTROL. The lower range of this volume control is like any other you've ever used. But as you increase it above mid-range, loud, shallow target response remains at a fixed volume while faint, deep target sounds continue to get louder.

PUSHBUTTON MANUAL GROUND ADJUST. It's no secret that a metal detector will perform its very best when manually tuned for actual on-site ground conditions. The only problem is that manual adjustments have always been confusing, complicated and time consuming. But not with the CZ-5. Just push the PINPOINT button and lower the coil to the

ground. Then set the GROUND control just below a threshold tone and you're ready to search.

EASY TO USE. Just pick it up, set the controls on the red marks and start searching in a "coins only" mode. It couldn't be simpler. Or for a maximum performance you can easily adjust the controls to your own particular situation.

SPIDER COIL. The eight-inch, open center Spider coil makes pinpointing even easier. It's lightweight, tough, Electro-Static Insulated (E.S.I. Shielded) and 100% waterproof.

TWO SEARCH MODES. A VLF-slow-motion discrimination mode for target identification and trash rejection. And a super hot, wide-scan auto tune mode for deep search all-metal treasure hunting and prospecting.

DROP-IN BATTERIES. No wires, no clips, no battery packs. Just drop in two 9V transistor batteries.

COMPACT. The CZ-5 breaks down and fits into an optional carrying case small enough to carry on most airlines.

HIP MOUNTABLE. Just slide the control housing off the shaft and onto your belt. What's left is so light it will feel like a part of your arm.

DOUBLE LOCKING NON-METALIC LOWER POLE. No shake no wobbles. No "lock-ring" to lose and no metal parts near the search coil.

LIGHTWEIGHT, BALANCED AND COMFORTABLE. Only three and 1/2 pounds light with a cushioned arm rest, foam grip, "S" handle and built-in detector stand.

Read this instruction manual thoroughly, practice often and you're in for some exciting treasure hunting. Drop us a line if you have any questions, comments or good finds to tell us about. In the meantime...

Happy Hunting!
Fisher Research Laboratory

CONDENSED OPERATING INSTRUCTIONS

FACTORY PRE-SET TURN-ON-AND-GO' MARKS

Your CZ-5 QuickSilver is fairly simple to operate, especially when compared to other target ID machines. Even so, we strongly recommend that you read this entire manual. You'll be able to tune your CZ-5 to your specific needs and conditions. And if you have a good understanding of how to do it and why, you'll find more.

But if you just can't wait any longer, and you're an experienced detector user, here's some quick instructions to get you going:

1. Set all the controls to the red "Turn-On-And-Go" marks:
GROUND = 5
DISC = 4
SENSITIVITY = 2
MODE = NORMAL
VOLUME = 5

This puts you in a "coins-only" mode and you're ready to start searching. Keep in mind that the GROUND setting of 5 is probably not the optimum setting for the ground you're searching and that's why the sensitivity level is set low—to reduce false signals caused by ground mineralization.

2. If you're using headphones, adjust the volume controls for a comfortable volume when the coil is passed over a large shallow object.
3. Walk slowly, overlap your sweeps and keep the search coil moving. Remember you are in a "motion" search mode and the coil must be moving at least slightly to detect a target.
4. When you get a good, repeatable signal, pinpoint the target by placing the coil on the ground away from the target, pushing and holding the pinpoint button and then bringing the coil back over the target.
5. Once you've pinpointed the target, note the approximate depth reading on the meter, then identify it by releasing the pinpoint button and moving the coil side to side in short strokes over the target. The meter needle will lock onto the appropriate target classification.
6. Good Hunting.

SETTING UP

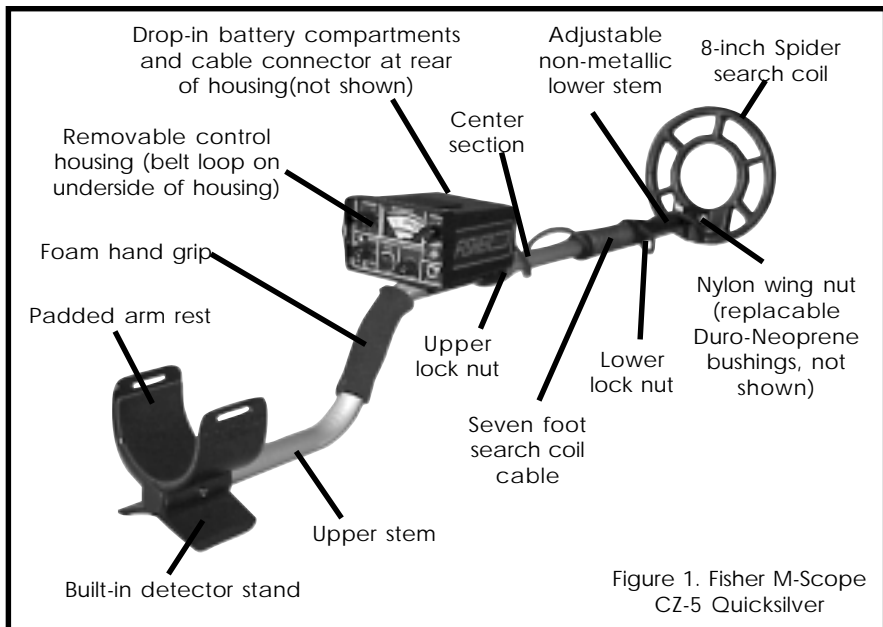

The CZ-5 comes to you just about ready to use. The only adjustment required is the angle of the stem. You may also wish to adjust the width of the armrest. Take a look at the diagram above and familiarize yourself with the parts of the CZ-5 before proceeding.

1. Unpack your new CZ-5 carefully. Save the carton and inserts—they may come in handy for future storage or shipment.
2. Take a look inside the locknut on the upper stem. Note the yellow locking pad on the left hand side and loosen the locking nut by rotating it fully counterclockwise.
3. Slip the lower stem into the upper stem; making sure the flat side of the stem is aligned with the locking pad inside the locknut.
4. Adjust the stem length (using the locknut) and the coil angle (using the nylon wing nut) so the search coil rests flat on the ground about 6 inches in front of, and slightly to the right of your right foot, (to the left of your left foot for left handers). Your arm should be straight and relaxed, the grip held loosely.

REMEMBER: THE LONGER THE SHAFT, THE MORE YOU WILL HAVE TO BEND YOUR ELBOW AND THE SOONER YOUR ARM WILL GET TIRED. THE CZ-5 IS BALANCED FOR COMFORTABLE SEARCHING IN A TIGHT SEMICIRCLE AROUND THE FRONT OF THE OPERATOR.

5. With the stem length properly adjusted, wrap the loop cable tightly around the upper stem and secure it with the two Velcro straps. Connect the cable connector to the control housing.

CAUTION: MAKE SURE THAT THE CABLE IS NOT PULLED TIGHT AT THE CONTROL HOUSING AND THAT YOU HAVE ENOUGH SLACK AT THE SEARCH COIL TO ADJUST IT TO ANY ANGLE.

6. With the shaft length and coil angle properly adjusted, you should be able to move into your "search" position (as shown in illustration below) by leaning forward very slightly and raising your arm (still straight) until the search coil is about 2 inches above the ground and 12 inches in front of your foot. The search coil should be parallel to the ground and may have to be slightly readjusted at this point.

7. If the armrest is too wide or narrow, you may bend it slightly inward or outward to meet your exact requirements.



Figure 2. Search Position

Adjust the stem length and coil angle so the coil rests flat on the ground about 6 to 12 inches in front of your foot. Move into your "search" position by leaning forward slightly and raising the coil about 2 inches off the ground.

This should put the search coil out about 12 to 18 inches in front of your foot.

HIPMOUNTING

1. Disconnect the cable from the control housing and unwind all but the last twelve inches or so from the stem. Secure the lower end of the cable with a Velcro strap at least twelve inches up from the coil.
2. Slide the control housing off the handle by holding the handgrip with one hand and pulling the housing towards you with the other hand.
3. Reconnect the cable to the control housing.
It is especially important that the cable connector be installed tightly to prevent false signals during hipmount use. Tight, but never tightened with anything but your hands.
4. Put your belt through the slots on the underside of the housing.
5. Left handers should wear the housing on their right hip and right handers on their left hip.

If you're working in shallow water you may want to hang the control housing around your neck or chest-mount with Fisher's Chest Harness. Just make sure you put it in a heavy plastic bag sealed tightly around the cable. Remember, the only thing waterproof about the CZ-5 is the search coil.

CONTROL PANEL

1. **GROUND:** Used to electronically cancel the effects of ground mineralization. Proper use of this control will minimize false ground signals and insure that the CZ-5 is operating at its maximum potential in just about any ground condition including wet ocean sand.
2. **DISC:** In the 0 through 6 position the CZ-5 is in the target ID mode, which is a silent, no-threshold motion-discrimination mode of operation with the ability to identify and then ignore ("reject") or accept many kinds of small metal targets. In the AUTOTUNE position, the CZ-5 is in an all-metal mode. In this mode, the CZ-5 has a wider and deeper search pattern; however, it lacks the ability to discriminate or identify and reject targets.

3. PINPOINT/DEPTH READING: A three purpose, spring loaded push-button. When pushed and held, the CZ-5 goes into a no-motion, all-metal mode for precise pinpointing and approximate depth reading of coin-sized targets. This button is also used in conjunction with the GROUND control during the ground balancing procedure.

4. SENSITIVITY/BATT TEST: In the extreme counter-clockwise position, the battery condition is checked as indicated by a strong or weak tone and a meter reading. When rotated clockwise, sensitivity to targets (as well as ground mineralization and electrical interference) is increased. When in the AUTOTUNE mode, this control also acts as a "threshold tone" control.

5. HEADPHONES: This connector accepts most stereo headphones.

6. MODE: NORMAL position for dry land or shallow fresh water hunting. SALT position for wet-sand ocean beaches or hunting in shallow surf.

7. VOLUME/OFF: Power on-off and volume control. Volume is gradually increased from 1 to 5 settings. From 5 to 10 loud target response is held constant while faint targets continue to get louder.

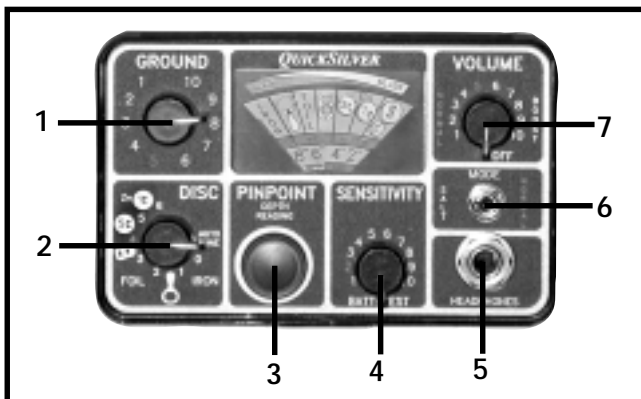

Figure 3, Control Panel

TURN ON PROCEDURE

1. Set your controls as follows:

GROUND = 10

DISC = 0 for normal use in target ID mode. (Set DISC to "Auto tune" for deep search, all-metal Auto tune mode.)

SENSITIVITY = 10

MODE = NORMAL (Unless you're on a wet ocean beach, in which case set the MODE switch to SALT.)

VOLUME = OFF

2. Hold the search coil waist high, away from any nearby metal.
3. Turn the VOLUME control to 10 (a brief bell tone is normal when you turn the VOLUME control on).
If you're in the Auto tune Mode, you'll hear an audio "threshold" hum. Lower the SENSITIVITY control until you can just barely hear it.
4. If you're wearing headphones, reduce the headphone volume controls to a comfortable level when the search coil is passed over a large, shallow target.

GROUND BALANCING

When your CZ-5 QuickSilver is properly "ground balanced," it will have only a minimum response to ground mineralization. Precise adjustment of the Ground control is critical. The higher the degree of ground mineralization or sensitivity setting, the more critical it is. Once you adjust it in either the Autotune mode or Target ID mode, you can switch back and forth between the two modes without resetting it, *unless you increase the sensitivity level or go from dry sand to wet sand or vice versa.* You should also recheck your setting occasionally as you search since ground conditions often change rapidly.

If you have difficulty ground balancing, try reducing your sensitivity level or moving to another spot just in case you are over a buried piece of metal. In some areas of high ground mineralization you may not be able to use the "Pushbutton" method.

“PUSHBUTTON” GROUND BALANCE METHOD

This will probably be your method of choice in all but the most difficult of ground conditions. It's fast, easy and accurate. You can use this method in either the Autotune or Target ID mode.

1. With your controls set as in the “Turn-On” procedure, (GROUND control at 10), hold the search coil parallel to and 6 to 12 inches off the ground. Press the PINPOINT button and hold it until you've completed step 2. Make sure you're at least three feet away from any metal objects.
2. Still pressing the PINPOINT button, lower the coil to the ground. Starting at 10, rotate the GROUND control clockwise until you hear an audio tone. Then back it off to the exact point where the tone disappears. Release the PINPOINT button and you're ready to search.

NOTES:

1. If you get an audio response as you first lower the coil with the GROUND control at 10, you're probably over a piece of metal. Move and try again.
2. If you get a sudden belltone not preceded by an increasing audio response as you lower the coil, you're probably in some very highly mineralized soil or sand. In this case, it's best to use the “Bobbing” method, paying particular attention to the notes under paragraph 7.
3. If you don't get any audio response, or just a very faint one as you rotate the GROUND control from 10 all the way to 0, you're probably in an area where there's very little ground mineralization. Just leave the GROUND control at 10 and begin searching.

"BOBBING" THE SEARCH COIL METHOD

This method takes a little more practice, but you may find it slightly more accurate (fewer false signals from ground minerals) in very highly mineralized ground (as in the note above), or if you are searching in the Autotone mode.

1. Set as in the "Turn-On" procedure, making sure the DISC control is at AUTOTUNE and the SENSITIVITY control is set so you can just barely hear a threshold hum. Hold the search coil parallel to and 6 to 12 inches over the ground and at least three feet away from any metal objects. *Do not use the PINPOINT button during any part of this procedure.*

2. Lower the coil to an inch or two above the ground and then quickly raise it. Note that as you lower the coil, the tone disappears, then gets louder as you raise it and finally returns to normal when you stop it 6 to 12 inches above the ground.

Conversely, if you set the GROUND control to 1, the threshold hum will get louder as you lower the coil and disappear when you raise it.

3. Your objective now is to adjust the GROUND control so that there is no change, or only a minimum change in the threshold hum, as you move the coil up and down. Start by lowering the GROUND control to 9. Lower the coil and raise it again. One of three things will happen to your threshold hum:

1) It will fade again as you lower the coil and increase as you raise it.

2) It will get louder as you lower the coil and go silent as you raise it.

3) The hum will remain the same, or if it changes slightly, the change is the same whether you lower or raise the coil.

4. If the hum remains the same or changes only slightly as in 3) above, your CZ-5 is properly ground balanced, and you are ready to begin your search.

5. If the tone fades as you lower the coil as in 1), continue to lower the ground balance setting in small increments until the threshold hum remains the

same (or changes very little) as the coil is lowered and raised.

6. If the hum gets louder as you lower the coil, you have gone past the correct ground balance setting. Increase the ground balance level (rotating the control counterclockwise) in small increments until there is little or no change in the threshold level.

7. With a little practice, you should be able to ground balance quickly by "bobbing" the coil up and down in a continuous movement as you adjust the GROUND control with your thumb.

NOTES:

1. If you get an audio response as you first lower the coil with the GROUND CONTROL at 10, you're probably over a piece of metal. Move and try again.
2. If you get a sudden bell tone, not preceded by an increasing audio response, you're probably in some very highly mineralized soil or sand. Instead of lowering the coil to an inch or two above the ground as in step 2 above, stop just before you hear the bell tone and ground balance as instructed. It will then be necessary to maintain that coil height as you search.
3. If you don't get an audio response, or if the hum stays the same no matter where you set the GROUND controls as you bob the coil up and down, you're probably in an area where there's very little ground mineralization. Just leave the GROUND control at 10 and begin searching.

SEARCH MODES

Your CZ-5 has two search modes: Target ID and Autotune. Both search modes are "motion" modes, meaning the search coil must be in motion to detect a target.

AUTOTUNE SEARCH MODE

Set the DISC control to Autotune and you're in a very sensitive, wide-scan, all-metal, motion search mode. Since this mode

responds to all metal targets and does not have the ability to identify or reject targets, this will probably not be your normal search mode.

The Autotune mode does have some advantages however which make it useful to use in at least two situations:

1. **Non-Trashy Areas.** Since the Autotune mode has a wider scan than the ID mode, you're less likely to miss a good target when using it. Search in the Autotune mode until you find a target. Pinpoint the target using the PINPOINT button and then switch the DISC control to "0" to identify it. The DISC control is positioned so that you can switch back and forth between Autotune and "0" with a flick of your thumb.

2. **Highly Mineralized Soil or Sand.** The Autotune Mode is recommended for black or gray sand beaches or highly mineralized soil. Under these conditions it may be necessary to lower the Sensitivity level and sweep several inches off the ground (see the note under paragraph 7 on page 10). Gold nuggets are generally found in highly mineralized soil so this will be the search mode of choice for prospectors.

TARGET ID SEARCH MODE

When the DISC control is set in the 0 through 6 position, the CZ-5 has the ability to identify many types of small targets and, depending on the discrimination level, reject or ignore most of them. To better understand just how your CZ-5 responds to different targets, try the following:

1. Scatter some sample targets such as coins, rings, pull tabs, nails and foil on the ground at least 18 inches apart. Include some large targets as well; jar lids, soda cans, etc.
2. Set the DISC control at "0", SENSITIVITY at "5", MODE at 'NORMAL', VOLUME at "10". (If you're wearing headphones, reduce the volume to a

comfortable level when you are over a large target.)

3. Ground balance the CZ-5 as in the "Ground Balance" procedure.

4. Hold the search coil about two inches above and parallel to the ground and move it slowly back and forth across each sample. Remember, the coil must be in motion to get a response. Keep in mind that for accurate target ID, the coil center must pass directly over the target.

5. Note the response you get over the small targets: For small iron or steel targets, the meter needle will usually lock in the "IRON" category. Most pull tabs, foil, nickels and the newer zinc pennies will also be correctly classified. Silver coins, copper coins, and the newer clad coins will ID in the highest category.

6. Note that an elongated ferrous object such as a nail will give you a double "beep" as you cross it from end to end and a single "beep" if you cross its center.

7. Most silver rings will ID at the highest end of the scale. If you have enough gold rings you will note that some fall in the round tab category, some in the "FOIL" category, some in the rectangular category, a few in the nickel category, and very few in the remaining coin categories. This is due to the fact that the combination of size, shape and conductivity of a particular ring will almost always add up to a target that is electronically identical to either a piece of foil, pull tab or nickel. Most metal detectors have a difficult time separating gold rings, nickels, tabs, and foil. But, the patented circuitry of your CZ-5 can easily tell the difference between nickels and most trash. Better yet, it will allow you to find many types of gold rings while completely ignoring at least some types of pull tabs and small pieces of foil.

8. Note also the different audio responses: an iron target will give you a low tone, tabs and foil a medium tone and coins a high tone.

pieces of tabs or aluminum are often misidentified; the tail of a round tab for example, may ID as a nickel. However, most tabs and most of the items on the CZ-5 meter face will be identified correctly.

11. Now increase the DISC control to "1". You will find that the CZ-5 rejects the small iron targets and no longer responds either with an audio tone or needle deflection.

12. Continue to increase your DISC control, noting that with each successive step up you reject more and more targets. At DISC = 4 for example, you are in a "coins-only" mode, ignoring iron, tabs and foil while accepting and identifying nickels, zinc pennies and silver, clad and copper coins.

13. At the maximum DISC level of 6 the CZ-5 will ignore most all-small targets except silver, clad and copper coins.

14. Now switch the DISC control to the AUTOTUNE position and note the completely different kind of response. No tone or meter identification, just a solid, smooth, response over every target.

15. The chart on page 15 shows some of the responses you may expect over different targets and at different levels of discrimination. Note that as you progressively increase the discrimination level you eliminate more and more targets.

NOTE: *Be aware that due to the virtually infinite variety of sizes, shapes and alloys of many "good" targets (relics, jewelry, foreign coins, etc.), they may be ID'd as just about anything. For example, a Civil War mini ball may be ID'd as foil, or a new Canadian coin as a rectangular pull tab.*

SEARCHING

Good search techniques are every bit as important as having a good detector.

1. Make sure your CZ-5 is properly ground balanced and the MODE switch is in the proper position: SALT for wet ocean beaches, NORMAL for just about every other situation.
2. Decide which search mode you're going to use, Target I.D. or Auto tune. *Recommended starting point: Target ID mode with the DISC control set at "4".*
3. Set your SENSITIVITY control. Only experience will tell you how to set it in every situation but you'll probably want to run it as high as you can. *Recommended starting point: SENSITIVITY 5 . If you're in the Autotune mode, set it so that you can just barely hear a slight audio hum.*
4. Adjust your VOLUME control. Remember that a setting above 5 will amplify the response of faint targets so that they sound like a shallow or large target. Some searchers prefer not to use it above 5 so that the audio response will give them some idea as to the depth and/or size of the target. *Recommended starting point: VOLUME = 10, then if you're using headphones, adjust the headphone volume controls for a comfortable, not-too-loud response over loud targets.*
5. Once you've got your controls properly set, begin your search by walking slowly and sweeping the search coil in a tight semicircle.
6. Keep the coil parallel to the ground and as close to the ground as practical. This is extremely important for maximum coverage and depth. If you're searching on a lawn, you may set the coil right on the grass and slightly "scrub" it.
7. Overlap your sweeps by at least 50%. Remember that your coil's search pattern is conical and if you don't overlap each sweep you'll miss the deeper targets.
8. Search in a methodical manner. Pay close attention to where you're going and where you've been.

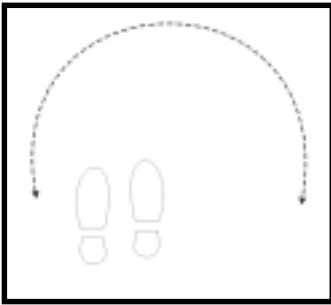

Figure 6. Search pattern.

When the stem length is properly adjusted, the CZ-5 is balanced for sweeping in a tight semicircle. Wide to the right for right hands. Wide to the left for left hands.

Be sure to overlap your sweeps.

9. Keep the search coil moving at a comfortable rate. Remember that the CZ-5 is a motion detector and responds only when the coil (or the target) is moving (except when in the Pinpoint mode).
10. Take your time. If you walk too fast you can't overlap your sweeps and you'll miss a lot of ground. If you swing your coil too fast you lose some sensitivity to deep and/or small targets.
11. The diagram on the next page shows the CZ-5 search coil pattern and how it is affected by sweep speed, ground mineralization and search mode.

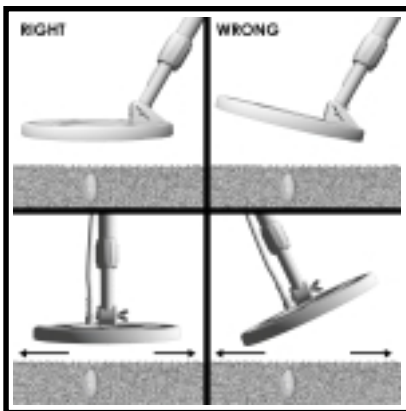

Figure 6. Keep the search coil parallel and close to the ground at all times.

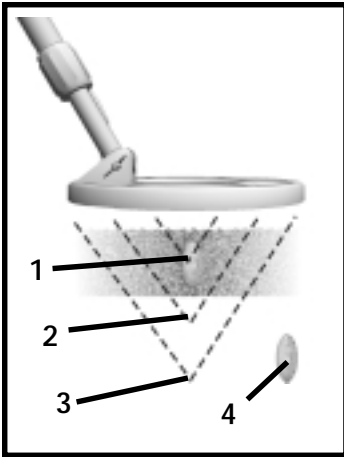

Figure 7. Search Coil
Detection Pattern

1. Minimum Depth
 - a. Very slow or fast sweep speed.
 - b. Discrimination set at "10."
2. Good Depth
 - a. Moderate sweep speed.
 - b. Discrimination set at "5."
3. Maximum Depth
 - a. Moderate sweep speed.
 - b. Discrimination set at "0."
4. Missed Target
Many targets within the range of your 1225-X will not be detected unless you closely overlap your swings.

Unlike other metal detectors, the discrimination level has little if any effect on the depth capability of the CZ-5. Note however, that the all-metal Autotune mode has a wider search pattern and may detect a little deeper. Depth is also determined by the size, shape and conductivity of the target as well as the sensitivity setting of the CZ-5.

PINPOINTING

PUSHBUTTON PINPOINT MODE

Target location is quick and easy using the pushbutton Pinpoint mode. You do not have to keep the coil moving to get a response in this mode.

1. Once the presence of a target is indicated by the “beep-beep” of your CZ-5, simply move the coil away from the target area, and with the coil lightly on the ground or very close to it, press and hold the PINPOINT button. (It doesn't matter which mode you're searching in, Autotune or Target ID.)
2. As you bring the coil back into the target area, still pressing the PINPOINT button, the audio volume and pitch will increase and the meter needle will swing to the right.
3. When the needle, pitch and volume are at their highest points, stop the coil and move it forward and backward a couple of times, again stopping over the strongest response.
4. Repeat one more time, side to side and then front to back, keeping the PINPOINT button pushed in and stopping over the spot where you get the maximum volume, pitch and meter reading. Your target should be directly below the center of your search coil. With a little practice, you'll find that you don't even need to look at the meter unless you want a depth reading.

For quick and accurate pinpointing of strong signals from large or shallow targets, push and hold the pinpoint button with the coil very close to the approximate target area. This will “tune-out” most of your target so you will only receive a response directly over or very nearly directly over it. You may also try reducing the sensitivity level and/or raising the coil so you can just barely hear the signal.

For very weak signals, make sure you press the PINPOINT button with the coil completely out of the target area. You may also try moving the coil closer to the ground or increasing the sensitivity and volume levels.

TARGET ID MODE AND AUTOTUNE MODE

Pinpointing in either of the search modes is more difficult but with practice you should be able to get the hang of it. (Many CZ-5 operators don't even bother with the Pinpoint mode unless they want a depth reading.)

Simply use the same basic procedure as you would using the Pinpoint mode, moving the coil side to side and front to back over the target area, stopping over the strongest audio response. The only difference will be that you should use as short of stroke as possible (four to six inches is plenty) and when you stop the coil, you will lose the audio signal. You **MUST** keep the coil moving at least slightly to determine the location of the strongest signal before you stop it.

TARGET IDENTIFICATION

Target ID is quick and simple; just keep in mind these four rules:

- 1) You must be in the Target ID mode. If you're searching in Auto tune, switch over to "0" on your DISC control.
- 2) For accurate identification, the center of the search coil must pass directly over the target.
- 3) There are many good targets, which are not classified by the CZ-5. As mentioned earlier, gold rings for example may fall in just about any category except iron. Many foreign coins, especially the newer ones, may ID as foil or pull tab. Gold nuggets, depending on their size and shape, may fall into just about any category, the smaller nuggets falling on the lower half of the scale. So if you're not just looking for U.S. coins, you should test some sample targets to determine what level of discrimination you want to work at and what targets you want to dig.
- 4) Your CZ-5 will correctly identify most small targets most of the time, but it can be fooled. Large targets, uneven ground mineralization, a good target lying next to a bad target, deep targets, all of these and more are sources of error. Remember, the CZ-5 is designed to ID small, coin size targets only, and even some of these may be deep, bent, damaged, or corroded enough to give a false signal.

1. Once you've located a target, pinpoint its exact location as in the "Pinpointing" procedure. *Since accurate ID is dependent on accurate pinpointing, it is recommended that you always press the PINPOINT button rather than try to pinpoint your target in either the Autotune or Target ID mode.*
2. Once you've pinpointed your target, release the PINPOINT button. If you're searching in the Autotune mode, switch over to DISC = 0. If you are already in the Target ID mode, just leave the DISC control where it is.
3. Move the coil just enough, left right left, across the target to get a good signal. The meter needle should lock onto a target classification, which in turn will agree with the audio response (high, medium, or low tone).
4. If you no longer get a meter reading or audio

response once you've pinpointed the target, then you're over something that falls below the DISC setting you've chosen and the CZ-5 is rejecting it.

DEPTH READING

Your CZ-5 Quicksilver will give you a quick and approximate (usually within an inch) depth reading of coin-size targets.

1. Place the search coil lightly on the ground at least twelve inches away from your target area.
2. Press and hold the PINPOINT button.
3. Still pressing the PINPOINT button, bring the coil back over the target and pinpoint its location by stopping the coil over the point where you get maximum pitch, volume and needle response.
4. Place the search coil lightly on the ground directly over the target, and still pressing the PINPOINT button, note the position of the needle over the depth reading scale. For example, if the needle is midway between the four inch and six inch marks, your target is approximately five inches deep.

You will quickly realize that the depth reading procedure is just like pinpointing, however there is one very important difference: when pinpointing is not real critical where or when you press the pinpoint button. In fact, it is often desirable to "detune" your target by pressing the button when the search coil is very close to your target and either on the ground or slightly above it. When taking a depth reading however, it is important that the coil be placed lightly on the ground at least twelve inches away from the target (or any other metal) before pressing the PINPOINT button. Also, remember that while you can pinpoint just about any size target, depth reading is only accurate for coin size targets.

TARGET RECOVERY

Once you have identified and pinpointed a target, your objective is to recover it quickly and neatly, leaving virtually no trace of your excavation. There are almost as many ways to do this, as there are Treasure Hunters. Whatever works for you is good enough as long as you don't break any laws, damage vegetation, or leave uncovered holes.

Generally speaking, beachcombers do little if any damage to the environment while recovering targets. However, if you plan to use your CZ-5 on lawns or in parks, your target recovery method can be very important. Two of the most successful methods are illustrated in a separate booklet enclosed with your CZ-5.

Whichever method you choose, remember that responsible Treasure Hunters take pride in their ability to leave soil and vegetation intact and undamaged.

RECOVERY TOOLS

1. A heavy duty, blunt screwdriver is commonly used by expert Treasure Hunters and is the tool of choice for cut lawns.
2. A sturdy hunting knife with a five inch blade will do the job on most other soils. A high quality double edge "survival" knife is an even better (and more expensive) choice since it will be almost impossible to bend or break.
***CAUTION:** Using a jack knife without a locking blade is a good way to lose a finger!*
3. A narrow garden trowel will work in loose or wet soil.
4. Several excellent digging tools are made just for the Treasure Hunter and especially designed sand scoops are available for beachcombing.
5. A thin, dull probe is the preferred tool for precise target location.

FALSE SIGNALS

A "false signal" occurs when a target is incorrectly identified. For example, a small broken-off piece of pull-tab may be identified as a nickel. Or a small deep coin, especially in mineralized soil, may read "IRON". The more sensitive the metal detector, the harder it is *not* to have false signals. Your CZ-5 is an extremely sensitive machine so you're bound to encounter them. Here are some of the most frequent sources of false signals and what to do about them:

1. **TRASH:** The most common source of false signals. Large or irregular pieces of trash may give positive, lock-on false signals. In this case you'll usually have to dig the target but with experience you'll be able to eliminate many of the large targets whose size will be obvious when you go into the pinpoint mode.

Another false signal response may be a "one-way" or disappearing signal. You'll sweep over the target and get a good signal but nothing on the

return sweep. When this happens you're over a target that the CZ-5 can't positively identify due to its size, shape, depth or alloy. The CZ-5 may ID it as a coin when swept from one direction and iron on the return sweep. If your DISC control is set at "0" you'll hear first a high tone (coin) and then a low tone (iron). Or if your DISC control is set higher, to reject iron, you'll hear the high tone sweeping one way and nothing the other way.

Quite often the signal will just disappear and you won't be able to find it no matter which direction you sweep. These one-way and disappearing signals are usually trash and as a general rule you should ignore them. If you have any doubts, press the PINPOINT button to get an accurate location and then ID the target. If you get a good repeatable, lock-on ID, dig it. If you still get a one-way signal or it disappears, move on. Also, if your pinpointing location is different than your ID location, your target is probably a piece of iron.

Reducing your sensitivity level or increasing the discrimination level may reduce the number of false signals caused by trash.

2. DEEP TARGETS: Deep targets, just barely within the range of the CZ-5 may be misidentified. For example, a deep coin may ID as iron or a deep piece of iron may ID as a coin. There's not much you can do to avoid this other than to use your pinpoint mode to insure that you are exactly centered over the target. Or you may reduce your sensitivity level so you just ignore the very deepest targets. Fortunately, misidentification of deep targets is not what usually happens. It's the exception to the rule.

3. ELECTRICAL INTERFERENCE: Constant chatter caused by radio/TV stations, power lines or nearby detectors operating at one of the CZ-5 search frequencies. The best solution is to move away from the source of the interference. You may also try

one of the following: Switch to the Autotune mode. Reduce your sensitivity level. Slow down your sweep speed. Use the optional 5 inch search coil. If the interference is only minimal and you wish to continue searching anyway, test your CZ-5 over a known target to make sure it's operating properly. Inside some buildings, electrical interference may be so bad that you'll have to go outside just to bench test your CZ-5.

4. HIGHLY MINERALIZED SOIL: May cause a belltone response or constant false signals. Check your ground balance (see the "GROUND BALANCE" section referring to mineralized soil), and make sure your MODE switch is in the proper position. If it is, try switching to the SALT mode and re-ground balancing. Try lowering the sensitivity and/or increasing the discrimination level. Search in the AUTOTUNE mode. Use the optional 5-inch search coil. Re-ground balance using the "Bobbing" method. If all else fails, raise the search coil just high enough for the false signals to disappear and then sweep at that constant height.

5. BLACK SAND: Same as HIGHLY MINERALIZED SOIL.

6. WET SALT WATER SAND: Your CZ-5 should be able to handle most wet sand easily unless it's black (see BLACK SAND above). Chances are, if you're having trouble in wet sand, you forgot to switch your mode switch to SALT and re-ground balance when you moved from dry to wet sand.

7. HOT ROCKS: Some rocks, by virtue of their high mineral content, will be seen by metal detectors as a metal target.

In the Autotune mode, the CZ-5 will respond to most hot rocks. Prospectors (who will most likely be using the Autotune mode in an area where hot rocks abound), however, will learn to distinguish between hot rock and nugget sounds. In the target I.D. mode, certain types of hot rocks will be automatically rejected at DISC = 0 and virtually all

other hot rocks will be identified as iron or rejected at DISC = 1.

8. "END OF SWING": Silent search motion detectors often give false signals at the edges of the search pattern—just as the coil stops and begins accelerating back toward the operator. If this is a problem, try one or more of the following: Keep your sweep smooth, slow and low to the ground. Check your ground balance. Lower your sensitivity. Make sure your search coil is properly secured and the cable connector is firmly tightened.

9. DIGGING TOOL: If you're carrying a metal sand scoop, digging knife, screwdriver or whatever, hold it behind your back or keep it above your waist. Your CZ-5 is sensitive enough to sound off each time you sweep the coil beneath it.

10. ELONGATED FERROUS OBJECTS: If you get two beeps close together and can't find either target, you may be near a nail or some other long, ferrous object.

Fortunately, in most cases your CZ-5 will identify these objects correctly, they just won't be where you think they are. In all cases, the target will be between the beeps, or if you sweep at right angles

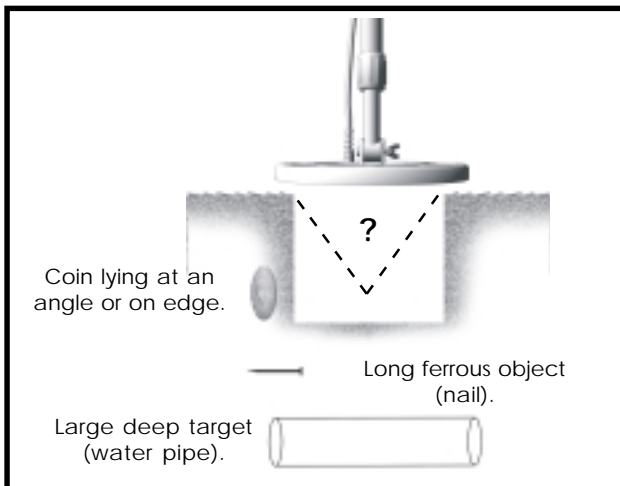

Figure 8. Targets that aren't there.

to your original direction, you'll receive a single beep directly over the target.

11. OTHER TARGETS THAT AREN'T THERE: Good lock-on, repeatable signals but nothing there.

a) Shallow coins (at or near the surface) or coins on edge will give a double beep, one on either side of the coin, just like a nail. Like the nail, the coin on edge will give a single beep directly over the target if you sweep at right angles to your original direction.

b) A coin lying in the ground at an angle may give a single target response but may pinpoint several inches away from its true location. Check around the inside edges of your hole. If you still don't find it, enlarge the hole by a couple of inches.

c) A large deep target, like a buried pipe or a manhole cover at two feet, will often give a good strong coin signal. If you get a depth reading of four inches and you've dug down a foot and widened your hole several times, give up.

OPERATING TIPS

1. Use headphones. You'll hear fewer distracting sounds and more target sounds. And you'll find more.

2. It's always a good idea to walk slowly and overlap your sweeps. But if you're searching large expanses of new territory you may want to walk a little faster and not overlap your sweeps as much until you start making a few good finds. Then, slow down, overlap your sweeps and cover every inch of ground.

3. In trashy areas, to reduce the "masking" effects of trash on nearby good targets, use a shorter and slower sweep pattern. Also, the optional smaller 5-inch search coil will zero in on good targets closer to trash.

4. Recheck your ground balance occasionally and make sure you haven't accidentally moved the MODE switch.
5. Here's a quick and easy way to tell the difference between a small shallow piece of foil and a gold ring (or other possibly good target) without digging: if you get a good solid, "FOIL" ID, set the search coil down close to the target and then whip it *rapidly* across the target just once with what can best be described as a flick of the wrist. If the target disappears, it's probably a small shallow piece of foil. If not, dig it up—it could be that gold ring you're looking for. Practice this over some foil until you get the hang of it.
6. Don't be afraid to turn your sensitivity down. True, the higher the sensitivity, the deeper your CZ-5 will go and the more you'll find. But that's only under optimum conditions. If you're getting a lot of false signals caused by electrical interference, ground mineralization or dense trash, lower your sensitivity. If you have to back it down to 4, 3 or even 2 to eliminate the falsing, do it. That's what your SENSITIVITY control is for. You'll be surprised at how much you might find in an area that would otherwise be unsearchable at high sensitivity levels.
7. Set your discrimination at an appropriate level. If there's very little trash in the area, set it low, say at iron discrimination and dig every good signal. If there is a lot of trash present and you're mainly interested in coins, set the discrimination level high—you may even want to sacrifice nickels and zinc pennies in extremely trashy areas. If you're looking for gold rings, relics, artifacts, or small ancient coins, you'll have to set your discrimination level low. The best way to find out how low is to bury some sample targets or just dig everything for awhile until you get a feel for which target classifications will be the most productive.
8. Look for repeatable signals and don't waste time on disappearing or one-way signals. If you hear a

good beep but can't repeat it when you go back over the target area, or if it beeps in only one sweep direction, it's probably a piece of trash—something below your discrimination setting.

9. If you're in a relatively non-trashy area, try searching in the Autotune mode and then identify your targets by switching to DISC = 0. You'll find more and deeper targets this way.

10. If you're having any difficulty pinpointing or identifying a target in the ID mode, don't waste any more time. Push the pinpoint button for quick pinpointing then release it for accurate ID.

11. If your target disappears when you go into the Pinpoint mode, you've probably tuned it out by pressing the button too close to the target or over another piece of metal. Try again, this time pushing the PINPOINT button over another piece of ground.

12. Don't waste a lot of time digging holes for targets you can't find if your hole keeps getting deeper and wider, cover it up and go on. You may be over a buried pipe or some other large deep target.

13. When in doubt, dig. If your CZ-5 can't quite decide whether a target is good or bad, dig it up.

14. Good things often come in twos. Or even threes. Once you've recovered a good target, always recheck the hole for a second signal and carefully search the immediate area by walking slowly around the hole two or three times, overlapping your sweeps in an ever widening circle. *Always dig every suspicious sound in the vicinity of a good find.*

15. Recheck your hole even if your find was trash. Good targets are often found beneath the bad ones.

16. Practice. Practice over known targets. Practice ground balancing. Practice pinpointing. Reread the appropriate part of this manual if you're having problems.

BATTERY REPLACEMENT

Check your batteries frequently by clicking the SENSITIVITY control counter clockwise into the BATT test position. The condition of the batteries will be indicated in two ways:

- 1) An audio tone. The stronger the better. A loud, high-pitched tone indicates good batteries. A weak, low-pitched tone indicates weak batteries.
- 2) A meter reading. Replace the batteries when the needle falls below gray BATT area. Two nine volt transistor batteries are located in a compartment at the rear of the housing. When it's time to replace them, always use alkalines and always replace both of them. (You may also use rechargeable Nicads but expect about 1/2 the battery life.)

1. Remove the battery door by loosening the two captive screws.
2. Tilt the housing slightly and the batteries will slide out.
3. Install the new batteries. Make sure the contact end goes in first and that you match the polarity markings on the battery door.

If either or both of the batteries are installed incorrectly, the CZ-5 will simply not turn on. The instrument will not be damaged.

4. Snug the screws down tightly—finger tight only. Do not use a screwdriver or other hand tool.

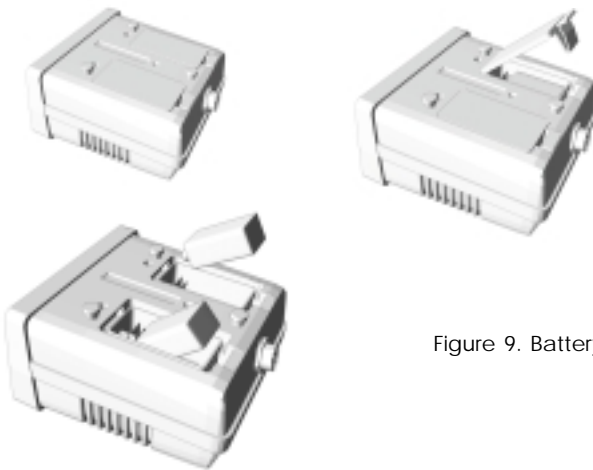

Figure 9. Battery replacement

MAINTENANCE

Your CZ-5 doesn't require a lot of care. It's built with high quality materials but there are a few things you should do to keep it in peak operating condition.

1. If you're not going to be using it for a while, take the batteries out. Acid damage caused by leaking batteries can be severe.
2. Avoid extreme temperatures. Don't leave it inside a closed car sitting in the sun, or even worse, the trunk of a car.
3. If you "scrub" the search coil on the ground, you'll eventually wear through the bottom of the coil. Replacement coils are expensive. Instead, invest in a coil cover. They're cheap.
4. Keep your CZ-5 dry and clean. If you've been working in or around salt water or dust, wipe it down with a damp cloth and dry it with a hair dryer (low or no heat) or dry cloth. Remove and clean the lower stem. Keep the lock nut free of sand and dirt.

TREASURE HUNTER'S CODE OF ETHICS

LET'S PRESERVE OUR TREASURED SPORT!

Laws governing the use of metal detectors are becoming more and more common. In many countries, the use of metal detectors is illegal or severely restricted. Don't let this happen in your area.

ALWAYS get permission to hunt on private property.

ALWAYS leave a site cleaner than you found it. Take at least some trash with you or, if you can, take it all.

ALWAYS fill in your holes neatly whether you're in a city park or remote wilderness. Leave the land as it was before you disturbed it.

ALWAYS obey all laws relating to Treasure Hunting.

ALWAYS return valuable property if you can locate the original owner.

ALWAYS do whatever you can to give the hobby of Treasure Hunting the good image it needs and deserves.

Where To Use Your Metal Detector In The U.S.

National Forest and Federal Lands—Metal detecting is allowed only by special permit acquired from the federal government. Each area has a district office.

Corps of Engineers, Lakes, Shorelines and Lands—Permission has been granted only on predisturbed sites, such as beaches and attached swimming areas. New Corps lakes and lands must be okayed by the main office of the Army Corps of Engineers. Each area has a district office.

State Parks and Lands—Some state parks are open to metal detecting, but some are not. Always check with the park ranger before attempting to use your detector.

Bureau of Land Management (BLM) Lands—Some areas are open for metal detecting, and some are not. Always check with the district office.

City or County Park Lands—Most are open to metal detecting unless notice is given by a sign or city ordinance. When in doubt, always check with the city's Parks and Recreation Department.

Public School Grounds—Most are open to metal detecting unless notice is given by a sign, city ordinance, law enforcement official, or school employee. You should always check with the school office first.

Privately Owned Lands (Private Property)—Permission required. And it is always best to have the permission in writing.

Historically Marked Lands or Sites—Metal detecting is not allowed. Don't even think about it.

SPECIFICATIONS

| | | |
|-----------------------------------|--|--------------------------------------|
| Length ² | Extended | 51 |
| Collapsed ³ | 41 | |
| Weight ² | Complete | 3.7 lbs |
| | Control Housing | 1.5 lbs |
| | Handle and Coil | 2.2 lbs |
| Frequency | 1. Dual, VLF Search ⁴ | 5 KHz and 15 KHz |
| | 2. Target Response | |
| Iron ID | 200 Hz (LO) | |
| Foil and Cable | 450 Hz (MID) | |
| Coin ID | 1 KHz (HI) | |
| Auto tone | 500 Hz 1 KHz (VCO) | |
| Pinpoint/Depth | 500 Hz 1 Hz (VCO) ⁵ | |
| Operating Modes | Auto Tone VLF-Motion ⁶ , all metal with threshold tone | |
| Target ID | VLF Slow Motion ⁶ , silent search discrimination | |
| Pinpoint/Depth | VLF, all metal, no motion | |
| Batteries | Drop-in, no wires | Yes |
| Type | Two, 9-Volt Alkaline ⁷ | |
| Life | 10-20 hours ² | |
| Manual Ground Adjust | Yes | |
| Manual Threshold Tuning | Auto tune mode only | |
| Wet Sand Operation | Yes ⁸ | |
| Handle Mount/ Hip Mount ... | Yes | |
| Universal Arm Rest/Detector Stand | | |
| Audio Output | Stereo Headphones (Optional) Speaker (Built in) | |
| Target-ID | Meter | Lock on, 7 categories |
| Tone | 3 tones plus bell tone for large shallow targets | |
| Faint Target Audio Boost | Yes ⁹ | |
| Search Coil | Type | Concentric, Co-planar Spider Coil |
| | Diameter 8" | |
| Shielding | 100% ESI ¹⁰ | |
| Interchangeable | Yes | |
| Submersible | Yes | |
| Warranty | Limited Lifetime ¹¹ | |

NOTES:

1. Subject to improvement or modification without notice.
2. Approximate.
3. The CZ-5 disassembles to fit into an optional carrying case measuring approximately 6" x 21" x 15".
4. The CZ-5 Fourier Domain Signal Analysis transmits two VLF signals simultaneously for deeper target ID in mineralized soil.
5. VCO: Voltage Controlled Oscillator. Volume and frequency increase as target is approached for pinpoint accuracy.
6. The CZ-5 is a motion detector in the AUTOTUNE and Target ID modes. The search coil must be moving at least slightly to detect a target.
7. For maximum performance and battery life, always use Alkaline Batteries.
8. Compensates for salt water and sand minerals simultaneously.
9. Volume control limits loud-target response, amplifies faint targets when level is set above 5.
10. ESI: Electro-Static Insulated to eliminate certain types of false signals.
11. The lengths and term of the warranty will vary outside the U.S. Check with your distributor for details.



QUALITY

Fisher detectors are renowned for their quality.
Each detector is hand crafted in the USA with pride

PERFORMANCE

Treasure Hunters worldwide rely on Fisher.
Our detectors are durable, dependable, and search deeper..

REPUTATION

Fisher produced the first patented metal detector in 1931. For
over 70 years, the Fisher logo has been a mark of excellence.

LIFETIME WARRANTY

Fisher believes in the products we produce and backs this
belief with a lifetime warranty, the best in the industry, on all of
our consumer detectors. Warranty may vary outside of the
United States. See your dealer for details

SERVICE

Fisher is committed to providing you, our valued customer, with
superior service. Each and every instrument is rigidly tested and
carefully inspected during assembly and before shipment.

Should you have any questions or problems, contact:

FISHER RESEARCH LABORATORY

200 West Willmott Road.,
Los Banos, California 93635
Tel 209.826.3292 Fax 209.826.0416
www.fisherlab.com email:info@fisherlab.com

EXPORT DEPARTMENT

P.O. Box 1896
New Haven, CT 06508 USA
Tel 203.288.1638 Fax 203.287.8099
email: mb@exportdept.com